



Apron series | Traditional style



www.oliverisinks.com

Oliveri offers two different materials for Apron sinks, High gloss ceramic commonly called Fire-clay or 16 gauge stainless steel. Clean angular contours and functional basins give a contemporary minimalist style that will be at home in the modern or traditional kitchen. Suitable for undermount installation in granite and other solid surface counter tops.

Apron series | Clay Style

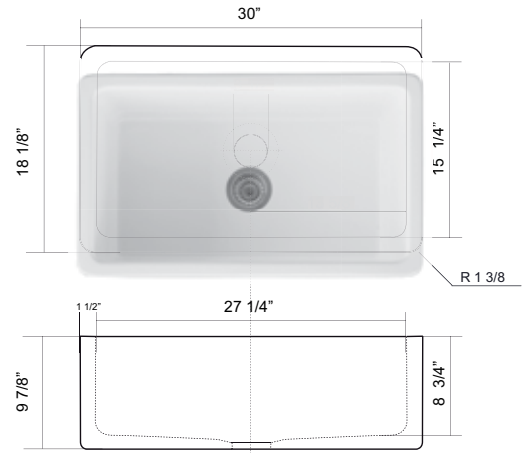

Apron series: 2280FC

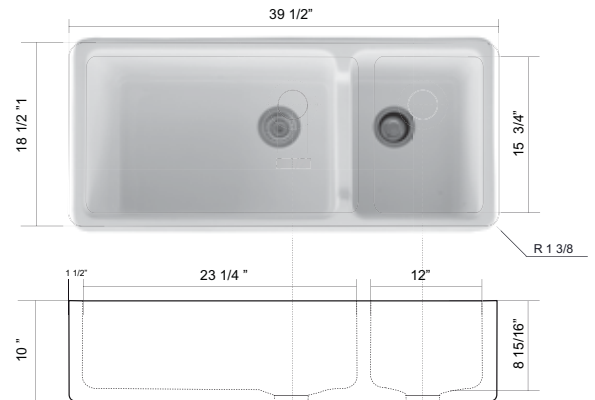

Apron series: 2286FC

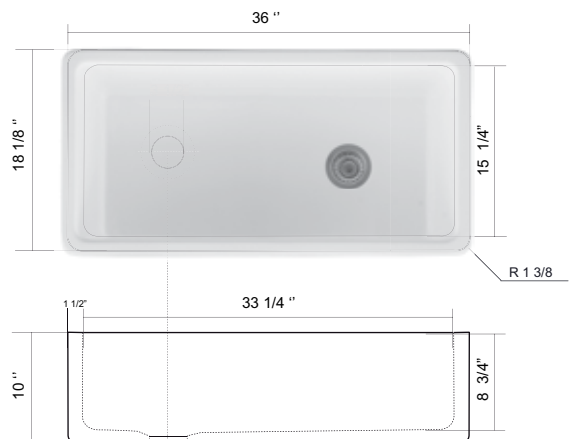

Apron series: 2290FC

Apron series | Stainless Steel Style

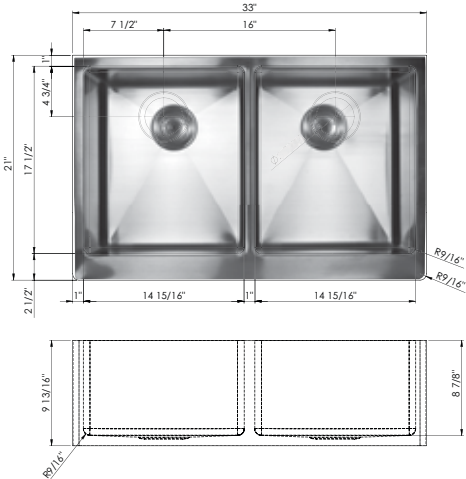

Apron series: 1263U

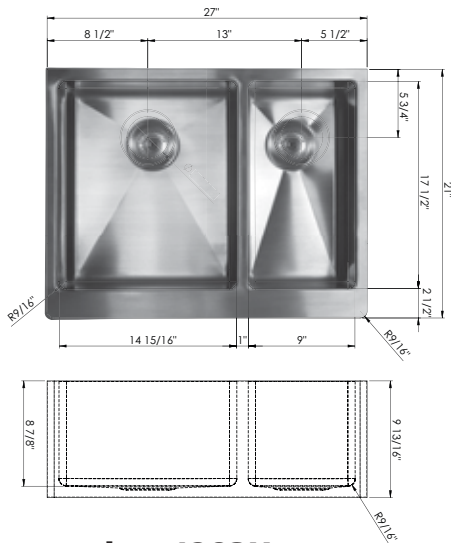

Apron series: 1283U

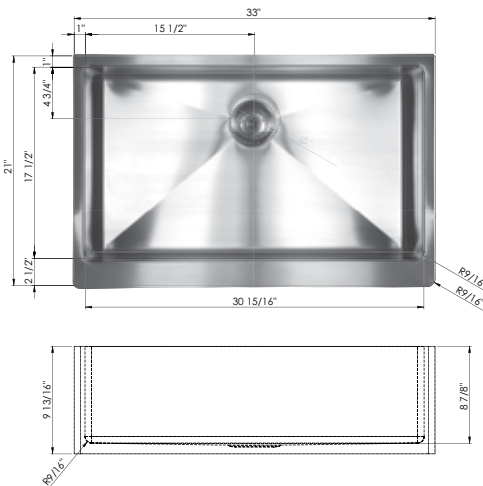

Apron series: 1290U

Sink apron
Protruding front apron provides a stylish addition to any kitchen.

Easy Clean Corners
The basins have tight radius corners which are hygienic & easy to clean.

Rear Outlets
Oliveri has placed the drain outlets towards the rear of the basin to give you the maximum amount of usable space below the sink.

18/10 Stainless Steel
Oliveri sinks are manufactured from genuine 18/10, 304 grade stainless steel.

Oliveri Logo
The Oliveri signature represents over 60 years of world class sinkware manufacture in Australia.





After Sales Service

Tasman Sinkware distributors support you with company trained technical specialists experienced in the production, installation, and care of Oliveri brand sinks and accessories. Here is what you need to do if you require service:

First: Contact the kitchen dealer or contractor who sold and/or installed the product. They should be able to solve any problems you may have.

Second: If your dealer or contractor can not solve the problem, they will contact or supply you with the name of the Tasman Sinkware distributor/agent who supplied the product and the name of their Oliveri technical specialist.

Third: If you are unable to obtain warranty service through either your contractor or the Tasman Sinkware distributor/agent, please write to Tasman Sinkware US Office.

Fourth: Include all pertinent information regarding your claim, including a complete description of the product, model numbers, and date the product was installed. Most of this information is on the identification label located on the underside of the basin. Also provide us the name of the installing contractor and distributor.

Warranty

Please take a moment to familiarize yourself with the Tasman Sinkware North America Warranty, its benefits, and limitations.

- 1 All Oliveri sinks carry Tasman Sinkware's Lifetime Limited Buyer Warranty.
- 2 Oliveri sinks are warranted free of manufacturing defects.
- 3 Tasman Sinkware shall at its election, repair, replace, or make appropriate adjustment where Tasman Sinkware inspection discloses any such defects occurring in normal usage. Tasman Sinkware is not responsible for installation costs, or consequential damages.
- 4 The warranty does not cover product failure caused by abusive treatment, surface scratches, misuse, or damage due to handling or faulty installations. This warranty is extended only to the original consumer purchaser of the product and excludes accessories and attachment products.
- 5 No additional warranties, express or implied are given. Any implied warranty including one of merchantability or fitness for a particular purpose are excluded.
- 6 To obtain warranty service, contact Tasman Sinkware either through your dealer or authorized Tasman Sinkware Distributor or write to Tasman Sinkware US Office.

World Class Manufacturing

Over the years, the Oliveri signature has earned its reputation as a mark of excellence in design, function and durability. Overseas markets have also been impressed by the quality and innovative accessories that complement every Oliveri sink. Export sales continue to grow, further establishing Oliveri as one of the world's best stainless steel sinks.

The company began life as a general, domestic and metal fabricator in 1948. The founders pioneered the deep drawing technology in Australia, creating seamless, deep drawn stainless steel basins.

Tasman Sinkware will continue to develop designs and styles suitable for any application where the highest standards are demanded.

Genuine Oliveri

Beware of imitations as no one can match the quality and design of Oliveri sinks and accessories. The Oliveri signature embossed into the stainless steel surface, as well as the distinctive Australian style packaging, ensures that your sink is a genuine Oliveri.

If it's not an Oliveri, it's a compromise.

Approvals

Many Oliveri products have been tested and approved for compliance with:

ASME A112.19.3
CSA-B45.0
CSA-B45.4 "N"

For specific information about compliance, contact your supplier.



Look for the brand with the blue dot

Head Office Australia
PO Box 2141 Regency Park
SA 5942 Australia
Phone 61 8 8348 6444
Fax 61 8 8348 6495
Website www.oliverisinks.com
Email sinkware@tasbuildpro.com.au

1230 Railroad Street,
Corona, CA 92882
Toll free 1 800 449 4401
northamerica@oliverisinks.com

**New Zealand
Dux Industries Ltd**
0800 FORDUX (0800 367 389)
dux@dux.co.nz

**Singapore
Sim Siang Choon Ltd**
6266 6632
sims@simsiangchoon.com

Axford Agencies
British Columbia - Head Office:
7 -1850 Hartley Ave.
Coquitlam, B.C. V3K 7A1
Phone- (604) 526-6361
Fax- (604) 526-6367
Website: www.xfordbc.com

**United Kingdom
A.C.Toon Ltd**
01246 223900
sales@actoon.co.uk

**Hong Kong
Deacon & Co Ltd**
2369 6111
imports@deacon.com.hk

RNG Marketing
Alberta, Manitoba, Saskatchewan -
Head Office:
129 McDonald Street N.
Regina, Saskatchewan S4N 5W2
Phone-(306) 359-7185
Fax- (306) 757-5031
Website: www.rngmarketing.com

Aquabross
Montréal - Head Office
9805 rue Clark St.
Montréal, Québec
Canada H3L 2R5
Tel: (514) 381-4141
Fax: (514) 381-4040
Toll free: (800)867-8484
Website: www.aquabross.com

Aquabross
Toronto
8899 Jane Street,
Concord, Ontario, L4K 2M6
Tel: (905) 660-4992
Toll free: (800)867-8484
Website: www.aquabross.com



www.oliverisinks.com



© Registered trademark of Tasman Sinkware. Under its policy of ongoing product development Tasman Sinkware may from time to time change product specification without notice. WARNING: Products in this brochure and all literature pertaining to, are subject to Intellectual Property Protection. All dimensions given are approximate and should be checked prior to installation. Product colour reproduction is as near to actual as printing methods allow.

Available from



A division of Fletcher Building